

NOTE:

- 1.MATERIAL SPECIFICATION:
 - 1.HOUSING:HIGH TEMPERATURE RESISTANT PLASTIC,UL94 V-0.
 - 2.CONTACTS:COPPER ALLOY
 - 3.MID PLATE: STAINLESS STEEL
 - 4.FRONT SHELL: STAINLESS STEEL
 - 5.EMI PLATE: STAINLESS STEEL
- 2.PLATING SPECIFICATION:
 - 2-1.CONTACTS:
 - Ni 50u" MIN. UNDER PLATED OVER ALL.
 - 3U"Au PLATED ON THE FUNCTIONAL AREA OF CONTACT.
 - 1U" Au PLATING SPECIFICATIONS OF THE SOLDER AREA
 - 2-2.FRONT SHELL:
 - Ni 30u" MIN. UNDER PLATED OVER ALL.
 - 2-3.MID PLATE:
 - Ni 30u" MIN. UNDER PLATED OVER ALL.
 - Sn 80u"MIN. PLATED OVER ALL
 - 2-4.EMI PLATE:
 - CLEAR ONLY
- 3.MECHANICAL PERFORMANCE,
 - 3-1.INSERTION FORCE: 0.5~2.0kgf.
 - 3-2.REMOVAL FORCE: 0.8kgf~2.0kgf.
 - 3-3.DURABILITY: 10000 CYCLES.
- 4.ELECTRICAL PERFORMANCE,
 - 4-1. CURRENT RATING:5.0A
VOLTAGE RATING:48.0V
 - 4-2. LLCR:
 - VBUS & GND PINS AND OTHER PINS: 40mΩ/PIN MAX.
 - LLCR MAX. CHANGE OF ALL PINS: 10mΩ.
 - 4-3.INSULATION RESISTANCE: 100MΩ MIN
 - 4-4.DIELECTRIC WITHSTAND VOLTAGE,AC 100V FOR 1 MINUTE.
- 5. ENVIRONMENTAL PERFORMANCE:
 - OPERATING TEMPERATURE: -25°C~+85°C.
- 6.IR REFLOW:
 - THE PEAK TEMPERATURE ON THE BOARD SHALL BE MAINTAINED FOR 10 SECONDS AT 260°C.

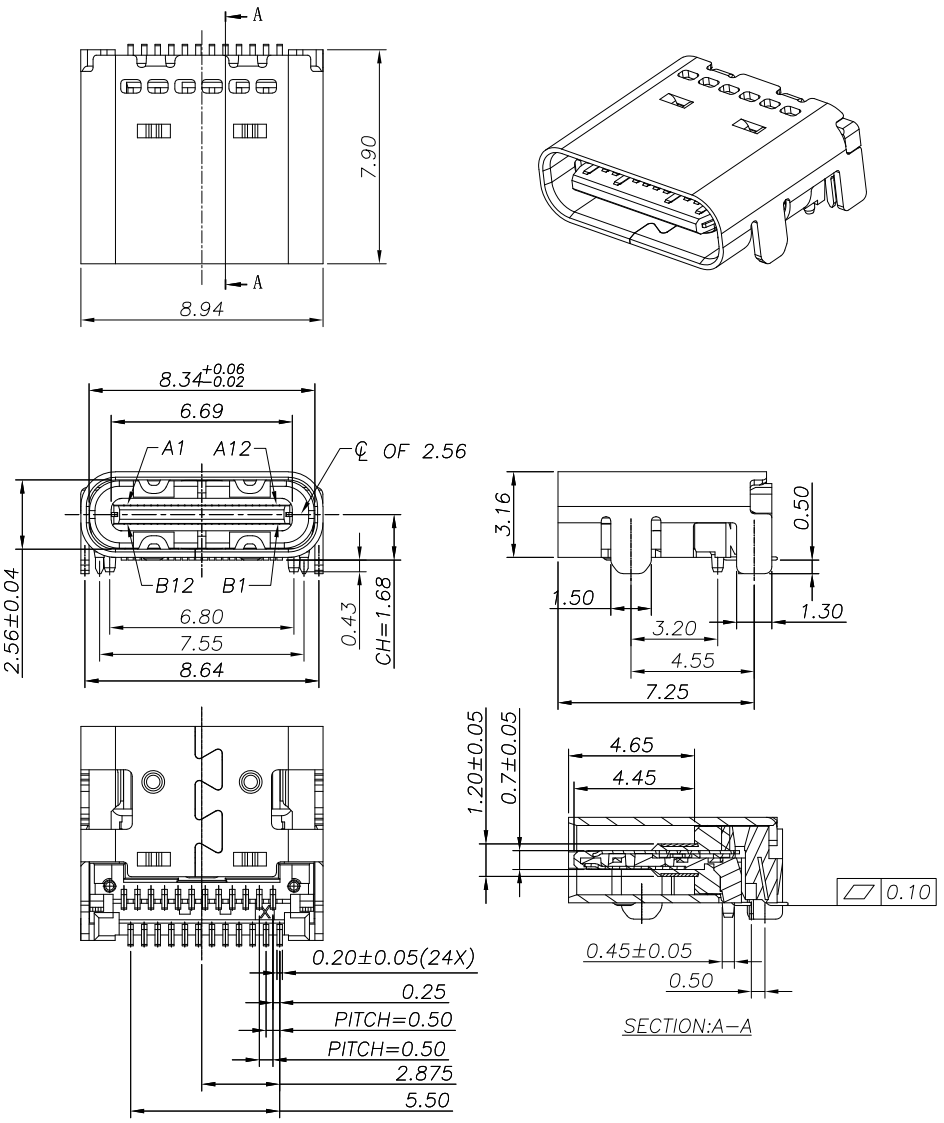

P/N: WUTC-2010-70

HOUSING PA9T
COLOR : BLACK

GOLD PLATING 3U"

TYPE C

REV.	ECN. NO.	DRAWN	DATE	EC.content
A.0	NEW	Candy	03/11/2025	-



⊗: QUALITY CONTROL ITEM	GENERAL TOLERANCE .X± 0.30 X.'± 2' .XX± 0.20 .X.'± 1' .XXX± 0.10	PART NO.: WUTC-2010-70
APPROVED		TITLE: USB CF 24PIN SMT TYPE TOP MOUNT WITH POST
CHECKED		
DRAWN	UNIT: mm	SCALE: 1:1 SHEET: 1/2 REV.: A.0

SIZE: A4

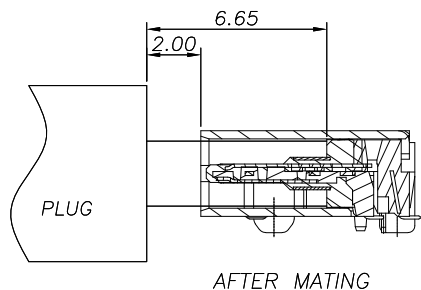

USB TYPE-C PIN ASSIGNMENTS

PIN NUMBER	SIGNAL NAME	PIN NUMBER	SIGNAL NAME
A1	GND	B12	GND
A2	TXp1	B11	RXp1
A3	TXn1	B10	RXn1
A4	VBUS	B9	VBUS
A5	CC1	B8	SBU2
A6	Dp1	B7	Dn2
A7	Dn1	B6	Dp2
A8	SBU1	B5	CC2
A9	VBUS	B4	VBUS
A10	RXn2	B3	TXn2
A11	RXp2	B2	TXp2
A12	GND	B1	GND

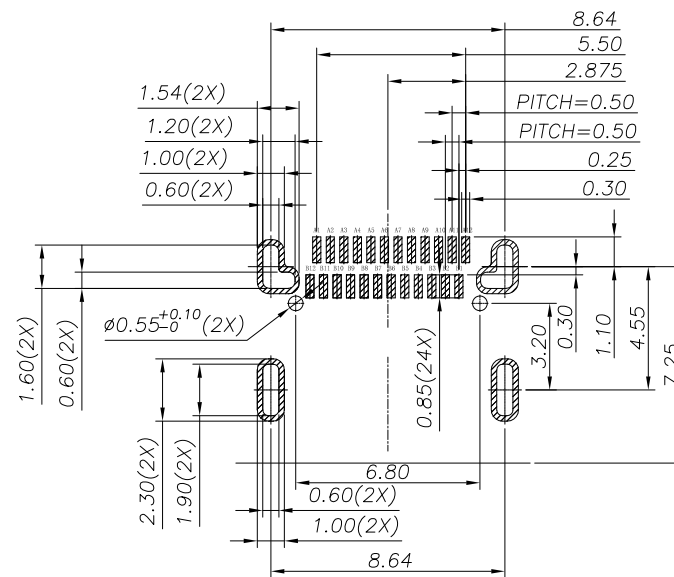

RECOMMENDED PCB LAYOUT(TOP VIEW)
THICKNESS 0.60MM;DEFAULT TOLERANCE:±0.05

REV.	ECN. NO.	DRAWN	DATE	EC.content
A.0	NEW	Candy	03/11/2025	-



⊗: QUALITY CONTROL ITEM		GENERAL TOLERANCE		PART NO.: WUTC-2010-70		
APPROVED		.X± 0.30	X'± 2'	TITLE: USB CF 24PIN SMT TYPE TOP MOUNT WITH POST		
CHECKED		.XX± 0.20	.X'± 1'			
DRAWN		.XXX± 0.10				
		UNIT: mm		SCALE: 1:1	SHEET: 2/2	REV.: A.0

説明: △: 備註 ◇: 版本變更 ⊙: 尺寸序號 ■: 重點尺寸 ▼: CPK 尺寸

DOCUMENT NO. : ZER0013/A.3

SIZE: A4